

7707CVT-4, 7707CVT-4-A16

Quad Analog Video, 16 Channel Analog Audio Fiber Transmitter



The 7707CVT-4 and 7707CVT-4-A16 are VistaLINK® -capable, composite analog video fiber transmitters for broadcast quality analog video and 16 analog audio signals. These card modules accept up to 4 NTSC or PAL analog video inputs and 16 analog audio, performs analog to digital conversion and transmits them over a single fiber. The companion 7707CVR-4 and 7707CVR-4-A16 Fiber Receiver demultiplexes the signals and converts them back to analog form.

The fiber optic output of these modules are available in an assortment of optical wavelengths, accommodating 1310nm, 1550nm, CWDM and DWDM transmission schemes.

The 7707CVT-4 occupies a single slot where as the 7707CVT-4-A16 occupies two card slots and can be housed in a 1RU frame which will hold up to 3 modules, a 7800FR 3RU frame which will hold up to 15 single slot modules, a 350FR portable frame which will hold up to 7 single slot modules or a standalone enclosure that will hold 1 module.

► Features & Benefits

- Single card fiber optic transmitter for up to four analog video and 16 analog audio signals
- Supports both NTSC and PAL video signals
- Broadcast quality analog video and audio performance
- Meets or exceeds EIA/TIA RS250-C short haul specifications for analog video transport
- Signal transport over fiber is uninterrupted by loss of input video feeds
- Comprehensive signal and card status monitoring via four digit card edge display or remotely through SNMP and VistaLINK®
- Supports single-mode and multi-mode fiber optic cable

- VistaLINK® capability is available when modules are used with the 3RU 7800FR or 350FR portable frame and a 7700FC VistaLINK® Frame Controller module in slot 1 of the frame
- Adjustable equalization for up to 250m of Belden 1694A coaxial cable
- Fully hot-swappable from front of frame with no fiber disconnect/reconnect required
- Optical output wavelengths of 1310nm, 1550nm, and up to sixteen CWDM wavelengths (ITU-T G.694.2 compliant)
- DWDM wavelengths (ITU-T G.694.1 compliant) also available

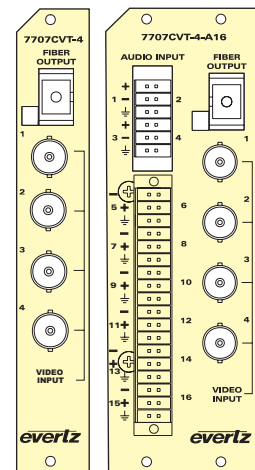
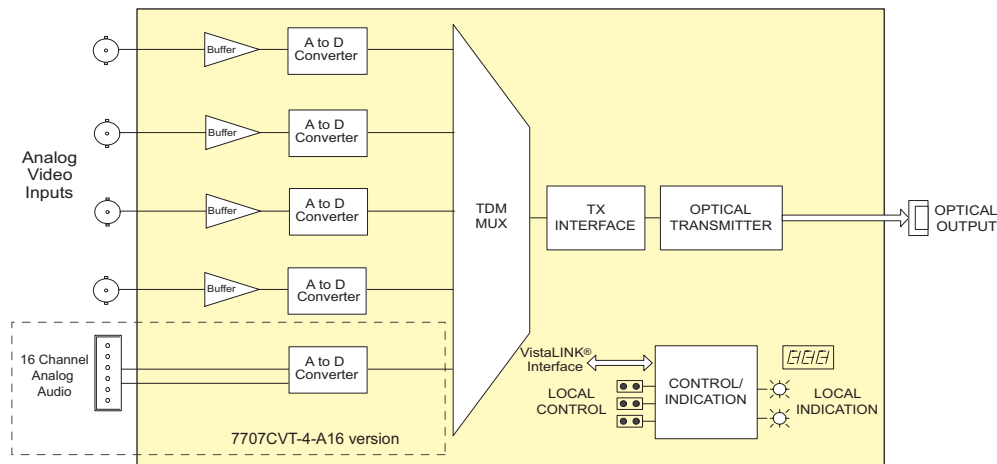

1
2
3
4
5
6
7
8
9
10
11
12
13

The Complete Solution Provider





► Specifications

Analog Video Input:

Standards: NTSC, SMPTE 170M, PAL, ITU-R 624-4
 Number of Inputs: 4
 Connector: 1 BNC per IEC 61169-8 Annex A
 Signal Quantization: 12 bits
 System Bandwidth: 5.5MHz
 Input Level: 2V p-p (maximum)
 Gain Equalization: up to 250m of Belden 1694A or equivalent (adjustable)
 Input impedance: 75Ω
 Return Loss: > 30dB to 5.5MHz
 Signal/Noise Ratio: > 70dB
 Differential Gain: < 1.0%
 Differential Phase: < 0.7°
 Passband Ripple:
 NTSC: < ±0.1dB to 4.1MHz
 < ±0.2dB to 5.5MHz
 PAL: < ±0.1dB to 4.8MHz
 < ±0.2dB to 5.8MHz
 Chroma/Luma Gain: 98% to 103%
 Chroma/Luma Delay:
 NTSC: < 5ns
 PAL: < 12ns
 Line Time Distortion: 1.2%

Analog Audio Inputs (7707CVT-4-A16):

Number of Inputs: 16
 Type: Balanced analog audio
 Connector: 48-pin removable terminal block
 Input Impedance: High Impedance (> 20kΩ)
 Freq. Response: ±0.1dB, 20Hz to 20kHz
 THD 20Hz-20kHz: < 0.005%
 Channel Phase Diff.: ±1°
 SNR (weighted): > 85dB
 Max. Audio Input Level: +24dBu
 Signal Quantization: 24 Bits

Optical Outputs:

Number of Outputs: 1
 Connector: Female SC/PC, SC/PC, ST/PC or FC/PC
 Return Loss: > 14dB
 Wavelengths:
 Standard: 1310nm, 1550nm (nominal)
 CWDM: See Ordering Information
 DWDM: See Ordering Information
 Output Power:
 1310nm FP (Standard): -7dBm ±1dBm
 1550 & CWDM DFB: 0dBm ±1dBm
 DWDM DFB: +7dBm ±1dBm

Electrical:

Voltage: +12V DC
 Power: 11/12W (Non-DWDM)
 13/14W (DWDM)

Physical (number of slots):

7707CVT-4
 350FR: 1
 7700FR-C: 1
 7800FR: 1
7707CVT-4-A16
 350FR: 2
 7700FR-C: 2
 7800FR: 2

Compliance:

Laser Safety: Class 1 laser product
 Complies with 24 CFR 1040.10 and 1040.11
 IEC 60825-1
 EMI/RFI: Complies with FCC Part 15, Class A
 EU EMC directive

► Ordering Information

7707CVT13-4 Quad Analog Video Fiber Transmitter 1310nm FP Laser, VistaLINK®
7707CVT15-4 Quad Analog Video, Fiber Transmitter 1550nm DFB Laser, VistaLINK®
7707CVT13-4-A16 Quad Analog Video, 16 Analog Audio Fiber Transmitter 1310nm FP Laser, VistaLINK®
7707CVT15-4-A16 Quad Analog Video, 16 Analog Audio Fiber Transmitter 1550nm DFB Laser, VistaLINK®

For CWDM, please refer to the end of the fiber section for ordering information

7707CVTxxx-4 Quad Analog Video Fiber Transmitter CWDM DFB Laser, VistaLINK®
7707CVTxxx-4-A16 Quad Analog Video, 16 Analog Audio Fiber Transmitter CWDM DFB Laser, VistaLINK®

For DWDM, please refer to the end of the fiber section for ordering information

7707CVTxxx-4 Quad Analog Video Fiber Transmitter DWDM DFB Laser, VistaLINK®
7707CVTxxx-4-A16 Quad Analog Video, 16 Analog Audio Fiber Transmitter DWDM DFB Laser, VistaLINK®

Ordering Options

Rear Plate and Fiber Connector must be specified at time of order
 Eg: Model +SC +3RU

Rear Plate Suffix

+3RU 3RU Rear Plate for use with 350FR, 7700FR-C or 7800FR Multiframe
+1RU 1RU Rear Plate for use with 7701FR Multiframe
+SA Standalone Enclosure Rear Plate

Connector Suffix

+SC SC/PC
+ST ST/PC
+FC FC/PC

Enclosures

350FR 3RU Portable Multiframe which holds up to 7 single slot modules
7700FR-C 3RU Multiframe which holds up to 15 single slot modules
7800FR 3RU Multiframe which holds up to 15 single slot modules
7701FR 1RU Multiframe which holds up to 3 single or dual slot modules
S7701FR Standalone Enclosure

- 1
- 2
- 3
- 4
- 5
- 6
- 7
- 8
- 9
- 10
- 11
- 12
- 13